

Marshall Electronics

VS-7300

5.0 MP IP Box Camera



User Manual

Firmware Version v1.0

Copyright ©2016, Marshall Electronics, Inc.
All Rights Reserved. This document may not be copied.

Trademarks

Other trademarks used in this document are registered trademarks or manufacturer or vendor trademarks associated with the products.

Disclaimer

Product options and specifications can be changed without notice. The information in this manual is furnished for informational use only and should not be construed as a commitment by Marshall Electronics, Inc. Marshall Electronics, Inc. assumes no responsibility or liability for any errors or inaccuracies that may appear in this publication.

Safety Precaution

**We appreciate your IP camera purchase.
Before installing the product, please read the following with care.**

- ✧ Make sure to turn off the power before installing IP camera.
- ✧ Do not install under direct sunlight or in dusty areas.
- ✧ Make sure to use the product within the temperature and humidity specified.
- ✧ Do not operate the product in presence of vibrations or strong magnetic fields.
- ✧ Do not put electrically conducting materials in the ventilation hole.
- ✧ Do not open the top cover of the products. It may cause a failure or electric shock on the components.
- ✧ Make sure to leave a space of at least 10 cm from the ventilation hole in order to prevent overheating.
- ✧ Check voltage and current requirements before connecting a power supply.

1. Introduction	4
1.1 About this Manual	4
1.2 Features	4
1.3 Product and Accessories	5
1.4 System Connections.....	6
2. Installation	8
2.1 Connecting Power	8
2.2 Connecting Network	8
2.3 Connecting Audio	8
2.4 Connecting Serial Port.....	8
2.5 Connecting Sensor & Alarm	8
2.6 Check If It Works	8
3. System Operation	9
3.1 Remote Video Monitoring	9
3.2 Initialization of IP Address.....	11
4. Remote Configuration	12
4.1 Using Web Browser	12
4.2 System Configuration	13
4.3 Video Configuration	21
4.4 Network Configuration	22
4.5 Serial Configuration	28
4.6 Event Configuration	30
4.7 User Configuration.....	36
4.8 Camera Configuration	38
5. VS Manager	42
7. Data Sheet	43
8. Appendix	45

1. Introduction

1.1 About this Manual

This User Manual provides information on installation setup, operation of the IP Camera, as well as troubleshooting tips.

1.2 Features

This product is a network-based box camera with live remote monitoring, audio monitoring and control via an IP network such as LAN, ADSL/VDSL, and wireless LAN.

Video

- Highly Efficient Compression Algorithm; H.264 & MJPEG support
- Wide range of Transmission Rates: 32kbps - 16mbps
- Various Transmission Modes: CBR, VBR, Hybrid
- Motion Detection

Audio

- Multi-Transmission Mode: Simplex (IP Camera to Client PC or Decoder/ Client PC or Decoder to IP Camera), Full Duplex

Network

- Fixed IP & Dynamic IP (DHCP) support
- 1:1, 1:N support
- Multicasting
- Various types of Protocol support : TCP/IP, UDP, Multicast, DHCP, SMTP, HTTP, SNMP, RTP, RTSP
- OnVIF, PSIA compliant

Serial Data

- RS-485 support
- Data Pass-Through Mode: Serial Data Communication between IP Camera and Decoder

Sensor and Alarm

- Supports direct connections of External Sensor and Alarm Devices
- Event Alarm

User Interface

- Diagnose and upgrade through dedicated program called VS Manager
- System configuration using Internet Explorer

High Reliability

- Reliable Embedded System
- System recovery by dual watch-dog functions

1. Introduction

1.3 Products and Accessories



**Megapixel IP
Box Camera**



Quick Manual

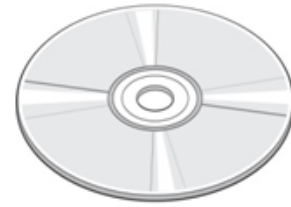

SW and User Manual CD

Part Names and Functions

Rear View



Connector	Function
1. Ethernet/802.3af	Ethernet port/802.3af LED : Booting and system check
2. Reset Button	Initialization of network setting
3. Audio In	Audio input
4. Audio Out	Audio output
5. Power In	DC 12V
6. Sensor / Alarm	Sensor input/ Alarm output
7. RS-485	RS-485 port
8. Composite Out	Composite Out
9. SD Card	SD memory card slot

1. Introduction

1.4 System Connections

The IP Camera can be connected in one of two ways:

1) 1 to 1 connection where one camera is connected to one PC client or a decoder system, or 2) 1 to many connections where one system can be connected to several PCs and decoder systems (the video server can work as a video decoder which takes the data from a video server or IP camera, decodes and outputs analog video).

Topology

Generally, the IP Camera and PC or a Decoder is connected in a 1-to-1 mode or a 1-to-many configuration:

● 1:1 Connection

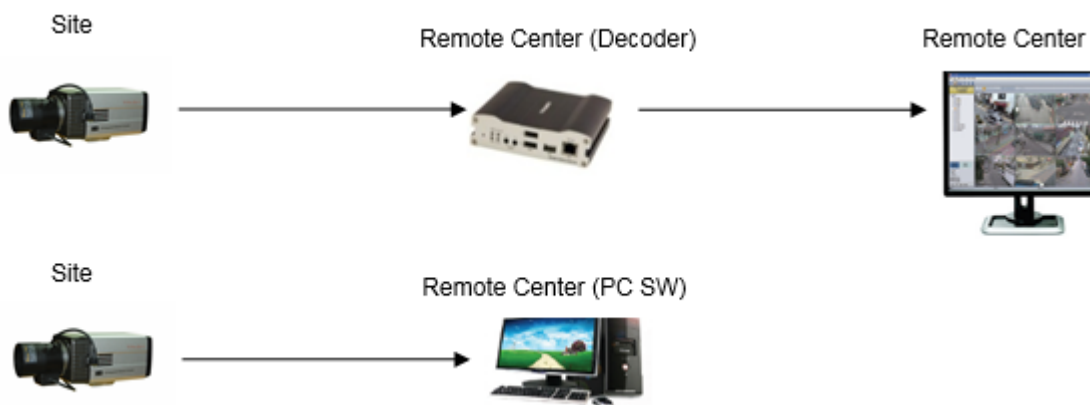

One camera is installed at a site where video images are transmitted. A PC or a decoder is installed at a central location to receive and view the video images on an analog monitor. Audio and serial data are transferred in either direction.

● 1:N Connection

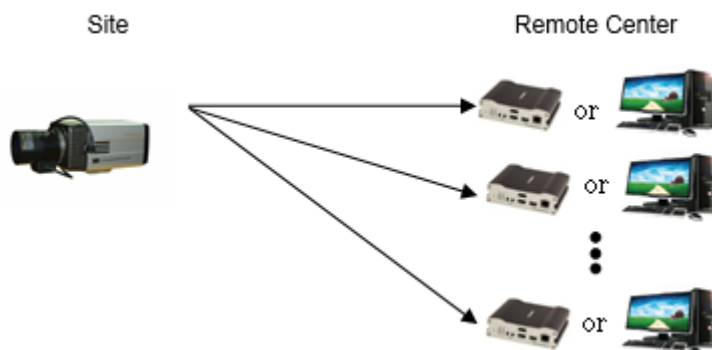

In this configuration, a site can be monitored from many remote central locations. Maximum connections would be limited by network bandwidth connection. Functionally, the VMS (Video Management System) software provided can replace the decoder.

1. Introduction

Multicast Mode

If the network supports **Multicasting**, a large number of decoders can be used to receive video effectively using a single video and audio streaming. However, Multicast Mode is possible only when the network environment supports Multicast.

- **Relaying**



In this arrangement, video and audio can be re-transmitted from one center to another center. The arrangement is useful when the network bandwidth at the site is limited while there is more than one center wanting to monitor the site.

- **VMS (Video Management System)**

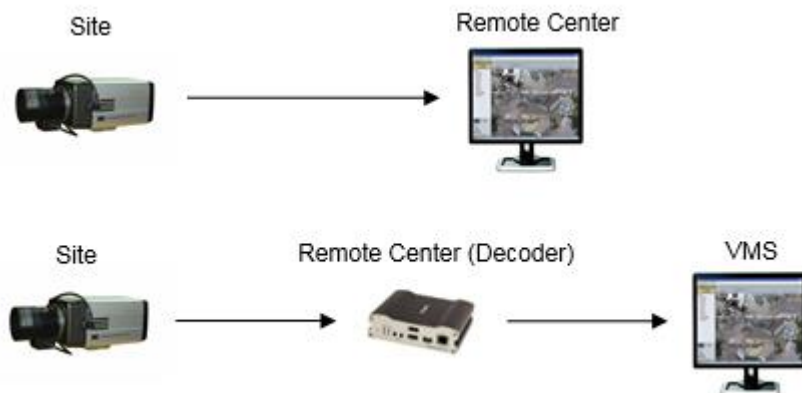

VMS (Video Management System) is a Windows based remote monitoring program to access multiple encoders for real-time monitoring or control of the encoders and connected cameras. Please refer to the VMS User Manual for more information on VMS.

2. Installation

2.1 Connecting Power

After confirming power source, connect power adaptor and 12VDC connector to the IP camera.

2.2 Connecting Network (LAN)

- Connect power to the IP camera
- Connect network cable into the ethernet port.
- To display video through the composite port, connect to a monitor and set preview option to ON.

2.3 Connecting Audio

Audio is **Full-Duplex**. It is possible to set the mode as **Tx-only**, **Rx-only**, or **Tx-Rx**.

- Connect audio input and output ports to audio devices accordingly.
- The audio signal required is line level, so audio equipment with an amp, mixer or other amplifier should be used.

2.4 Connecting Serial Port (RS-485 Communication)

This IP Box Camera can be connected to external equipment such as a PT receiver, etc. The camera can send PT commands via the Serial Ports.

When a Decoder System is used to connect the IP Box Camera to the Serial Port, the Decoder System works in Pass-Through Mode (data from one port is delivered to the other port).

2.5 Connecting Sensor and Alarm

Connect Sensor and Alarm Devices to corresponding terminals accordingly.

2.6 Check If It Works

Once the power is supplied to the camera, it will start booting. The system will boot up to operation mode after approximately 40-60 seconds. The green LED on the Ethernet Port will flash indicating the system is ready.

Software provided on the disc called **VS Manager** allows you to check the IP address and other network details of the camera. Please refer to the VS Manager manual for instructions on how to find the IP address of the camera and to make necessary changes.

3. System Operation

3.1 Remote Video Monitoring

There are two ways to monitor video when the VMS (Video Management System) and IP Camera are connected. In order for a proper operation, an IP Address must be set accordingly. Please refer to the **VS Manager Manual** enclosed with product for further details.

Default ID: admin	Default Password: 1234
--------------------------	-------------------------------

Video Monitoring using Internet Explorer

Open Internet Explorer and enter the Camera's IP Address. The system will ask for confirmation to install Active-X Control. Once authorized, Internet Explorer will begin to display video images from the Encoder as shown below:

Default IP Address : http://192.168.10.100

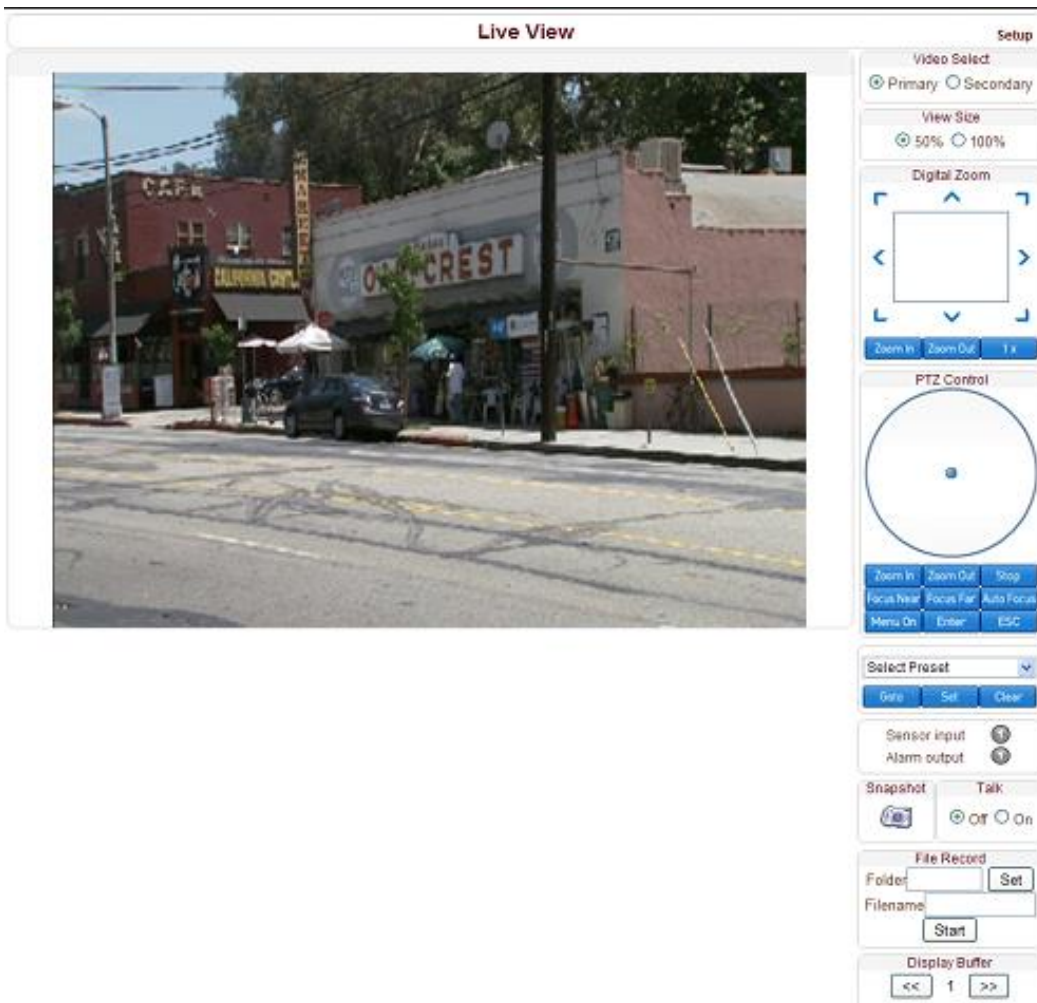

3. System Operation

- **Video Select**

Select the Video Stream to be viewed: **Primary or Secondary**.

This camera is capable of **Dual Streaming**; Primary Streaming and Secondary Streaming. Video will be displayed according to the resolution set on video configuration. If Dual Streaming ("**Use Dual Encode**" **Menu in Video page**) is not activated, Secondary Video is not available.

- **View Size**

Adjust the Screen Size. Screen size is initially adjusted according to the **Compression Resolution**. If you click 50% icon, the whole screen size will be reduced to half size.

- **Digital Zoom**

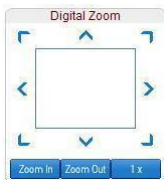

Control the Digital Zoom on the screen.

The more the camera zooms in, the smaller the square of control panel is. Position of the image can be changed by moving position of the square. If you press "**1x**", the screen will return to the normal size.

- **PTZ Control (Optical Zoom & Digital Zoom Built-In Camera)**

PTZ Control Panel is used for controlling External PTZ devices when the External PTZ devices are connected through a special Serial Port. It is possible to control zooming by using the **Zoom In/Out** buttons of PTZ Control Panel. In order to use Digital Zoom, select **Digital Zoom "ON"** in the **Camera Tab**)

- "**Stop**"
Stop on-going action.
- "**Focus Near**", "**Focus Far**", "**Auto Focus**"
Adjust the focus of the lens.

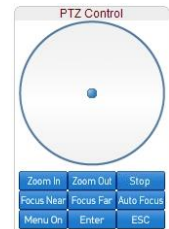

- **Select Preset**

Set preset position and move to the specific preset position.

- **GoTo**: After set up, move to the selected preset entry.
- **Set**: Set the current position to the selected preset entry.
- **Clear**: Delete the selected preset entry.

- **Sensor Input**

Displays the status of the sensor in real time. This camera supports **One Sensor Input**. When the sensor of the camera is working, the sensor light turns red.

- **Alarm Output**

Operate the Alarm Device by pressing the number icon. This encoder supports **One Alarm Output**. A number icon indicates the status of the alarm device.

3. System Operation

- **Snapshot**

Capture video images and save them as BMP or JPEG files.

- **Talk**

Transfer audio from the PC microphone to the camera.

- **File Record**

Recording to an AVI file on Live View page is available. AVI files are generated in the specified folder or in specified file name on the PC where the web browser is running.

1. Press “**Set**” button to select folder or create a new folder. Enter the file name on Filename field.

2. Press “**Start**” button to start recording.

3. Press “**Stop**” button to end recording.

4. AVI file named “**IP address_hh_mm_ss**” or “**File name_IP address_hh_mm_ss**” will be generated in the specified folder depending on whether the path specified a folder or a prefix of the file name.

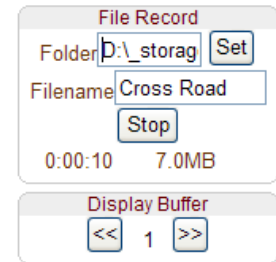

- **Display Buffer**

Set the number of video frames to be buffered before being displayed on web browser. Larger values result in smoother video by sacrificing the latency. A setting of 10 -15 frames can be generally used for most situations.

Video Monitoring with Decoder System

When the Camera’s IP Address is set in the Remote IP Address section of the Decoder, the Decoder System will connect to the Encoder and start receiving the video images. Normally, a monitor connected to the decoder will display video images.

3.2 Initialization of IP address

If a System IP Address is lost, the system can be reset to the System Default IP Address using the Reset Button to the left of the LED lights.

1. While system is in operation, press the reset button for more than 5 seconds.
2. The system will reboot automatically.
3. Once the system reboots, IP Address will be set to the System Default as below:

• IP Mode	Fixed IP	• IP Address	192.168.10.100
• Subnet Mask	255.255.255.0	• Gateway	192.168.10.1
• Base Port	2222	• HTTP Port	80

4. Remote Configuration

4.1 Using Web Browser

Remote Setting is available by using web browser. Enter IP Address of the Camera and a Live View screen appears (see below). Press the **Setup** button located in the upper right area of the monitoring screen for Server Setup. For Remote Setting, the user should have manager-level authority or higher.

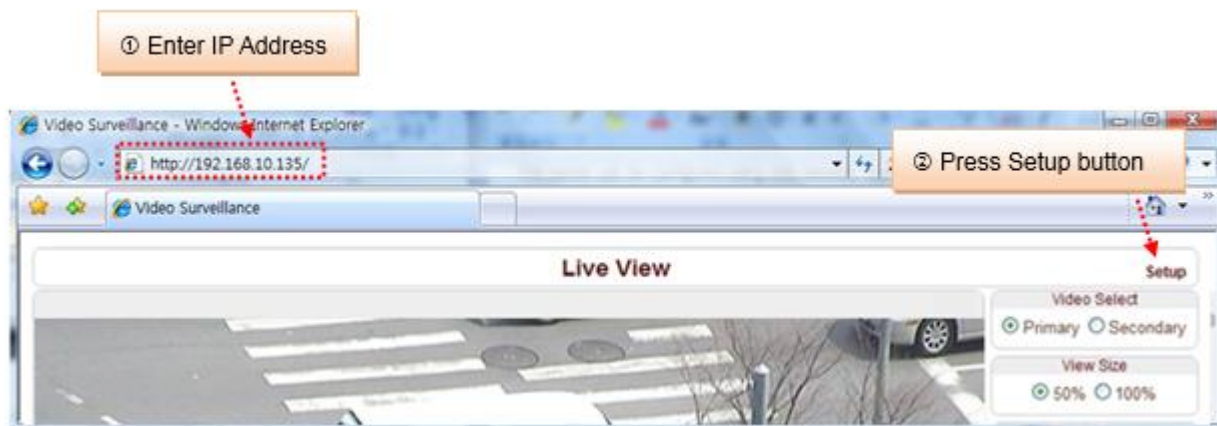

The configurations are grouped into 9 categories: **Video & Audio, Image, Network, Event, Record, Device, PTZ, System, and User**. To save configuration changes, click "**Apply**". Leaving the page without clicking "**Apply**" will discard any new changes.

4. Remote Configuration

4.2 System Configuration

Setup Live View

SystemVideoAudioNetworkSerialEventPresetRecordUserCamera

System

General

System ID

BurnIn OSD System ID (alphanumeric characters only)

Language ▼

Firmware

Version

Board ID

Upgrade

Config Backup&Restore

Backup

Restore

Time

Start Time

Current Time

Time Format ▼

Time Zone ▼

Automatically synchronize with NTP server

NTP Server Name

Reboot

Factory Reset

4. Remote Configuration

General

- **System ID**
Enter System ID for the camera. The System ID is displayed on the video image and is transferred to the remote software, such as VMS.
- **Language**
Select the language to be used for web-based configuration.

Firmware

- **Firmware Version**
Firmware version will be displayed here.
- **Board ID**
The Network Camera Board ID will be displayed here.
- **Upgrade**
To upgrade firmware, **Browse** local drive and select firmware file. Press **Firmware Upgrade** to begin upgrade. Status messages (downloading / upgrading) will be displayed. The camera will reboot automatically after completing upgrade. **Do not turn off the camera during upgrading.**



Config Backup & Restore

- **Backup**
All configuration settings can be saved.
- **Restore**
Browse configuration settings and select to restore. The server is rebooted when **Config Restore** is selected.

Time

- **Start Time**
Camera's most recent booting date and time.
- **Current Time**
Enter the date and time and select **Set Current Time** to update.

4. Remote Configuration

- **Time Format**

Select the time and date format:

- YYYY/MM/DD hh:mm:ss (Ex. 2010-4-11 18:18:42)
- DD/MM/YYYY hh:mm:ss (Ex. 11-4-2010 18:18:42)
- MM/DD/YYYY hh:mm:ss (Ex. 4-11-2010 18:18:42)

- **Time Zone**

Select the time zone of where the camera is installed. Depending on the time zone, Daylight Saving Time will work automatically.

A **time zone** is a region of the earth that has uniform standard time, usually referred to as the **local time**. By convention, time zones compute their local time as an offset from UTC (Coordinated Universal Time). In casual use, GMT (Greenwich Mean Time) can be considered equivalent to UTC. Local time is UTC plus the current time zone offset for the considered location

- **Automatically synchronize with NTP server**

Synchronize the camera time with the NTP server time (network time protocol). NTP server name should be registered.

The **Network Time Protocol (NTP)** is a protocol for synchronizing the clocks of computer systems over packet-switched, variable-latency data networks. It is designed particularly to resist the effects of variable latency by using a jitter buffer.

Reboot

- Reboot the camera. Only reboot when server needs a reboot.

Factory Reset

- Clear all settings including user accounts and logs.

Factory Reset except network settings

- All the settings except for current network settings are changed to default values.

4. Remote Configuration

4.3 Video Configuration

Setup Live View

System **Video** Audio Network Serial Event Preset Record User Camera

Video Apply

Encode

Enable Preview Off On

Resolution

Framerate

Preference

Quality

Bitrate kbps (32 - 10240)

I-Frame Interval

H.264 Profile

Dual Encode

Use Dual Encode Off On

Dual Encode Algorithm H.264 MJPEG

Resolution

Framerate

Preference

Quality

Bitrate kbps (32 - 2048)

I-Frame Interval

H.264 Profile

Motion Detection

Use Motion Detection Off On



Edit Enable Disable Erase Apply Edited Area

Mode Set Erase

Sensitivity(0 for most sensitive)

Information Display

SystemID Off On

Time Off On

Position Bottom Top

BurnIn OSD

SystemID Off On

Time Off On

Position Bottom Top

Font Size

Output Format

Output Format

4. Remote Configuration

Encode

- **Enable Preview**
 1. Select **ON** to enable the video display preview on the monitor.
 2. Select the **Output Format** based on the video preview. Note: when **Enable Preview is ON**, dual streaming is not available. When the video is transmitted directly to the monitor through the BNC cable, the video is not sent through the network. Therefore, video has less delay and no network limitations.
- **Resolution**

Select video encoding resolution.
- **Framerate**

Determine the **maximum number of frames per second** for the video stream. 1, 2, 3, 4, 5, 6, 8, 10, 15, 20, 25 and 30 frame rate can be selected. The actual frame rate of video can be less than the maximum frame rate set due to the network bandwidth limitation.
- **Preference**

Select Encoding Mode to control the **Video Quality** or **Bitrate**: Quality (VBR) or Bit Rate (CBR). If 'Bitrate' is selected, the video encoding will be effected by the 'Bitrate' value entered. Therefore, the "Bitrate" mode corresponds to CBR (Constant Bit Rate) encoding. If 'Quality' is selected, the video encoding will be effected by the quality of image selected. Therefore, the "Quality" mode corresponds to VBR (Variable Bit Rate) encoding.
- **Quality**

Select Quality Level: 7 Levels of Quality are available. **Quality Mode (VBR Encoding)** encodes every frame in a constant quality. Therefore, resulting bitrate may vary a lot depending on the complexity or activity changes in the input video. Quality Mode is preferred when constant video quality is required and the network bandwidth is enough for delivering the stream of highly varying bitrate.
- **Bit Rate**

Bitrate value ranges between 32 and 16Mbps. **Bitrate Mode (CBR Encoding)** allows you to set a fixed target bitrate that consumes a predictable amount of bandwidth. In order to stay within the bitrate limit, video quality is controlled dynamically according to the complexity or activity changes in the input video.
- **I-Frame Interval**

Determine I-Frame Interval between 1 and 255.
- **H.264 Profile**

Select the H.264 Profile: **High Profile** or **Baseline Profile**.
A profile defines the various capabilities which target specific applications.

4. Remote Configuration

1. High Profile

High Profile is the primary profile for broadcast and disc storage applications; particularly for high-definition television application (for example: Blu-Ray Disc storage format and DVB HDTV broadcast service).

2. Baseline Profile

Baseline Profile is for low-cost applications that require additional data loss robustness used in some videoconferencing and mobile application. This profile includes all the features that are supported in the constrained baseline profile, plus three additional features that can be used for loss robustness.

Dual Encode

• Use Dual Encode

1. **Enable Preview** should be **OFF**.
2. Select **ON** to enable Dual Encoding.

The secondary video can be viewed on the **Live View** window by selecting **Secondary** on **Video Selection**.

• Dual Encode Algorithm

Select H.264 or MJPEG for the secondary streaming.

H.264 supports either **Bitrate Mode** or **Quality Mode**. However, MJPEG supports **Quality Mode** only.

Motion Detection

• Use Motion Detection

Turn ON **Motion Detection** function.

• Motion Detection Area Editing

Configure regions for motion detection. Regions of arbitrary shape can be configured by the following steps:

1. Select **Enable** on **Edit** tab.
2. Select Editing Options: **Set** includes cells to motion detection region and **Erase** is for excluding.
3. Select cells by using the right button of the mouse. Multiple cells can be selected by holding and dragging.
4. Select **Apply Edited Area** to save edits.

4. Remote Configuration



- **Sensitivity**

Sensitivity will trigger a motion detection event.

This value determines the sensitivity of the motion detection within a block. This is selectable from 0-10; the smaller the number, the more sensitive the motion detection becomes.

Information Display

System ID and/or Time can be displayed within the video in Internet Explorer. Each item can be turned on/off separately. The position for each item can be configured individually as well. This information is displayed **after the video is decompressed**.

BurnIn OSD

Insert System ID and Date/Time **in the compressed video**. Each item can be turned on/off separately in the video. Position and Font Size can be configured as well. System ID for BurnIn OSD exists independently from normal System ID.

Note: BurnIn OSD Display Size varies according to the encoding resolution setting. This is inevitable because BurnIn OSD is inserted to the frames before encoding is performed. The following table describes the rule for BurnIn OSD display:

4. Remote Configuration

Resolution	Small (8x8)	Middle (16x16)	Large (32x32)
352x480 / 352x240 / 352x576 / 352x288	2	1	0
720x480 / 720x240 / 720x576 / 720x288 / 640x480 / 800x600	2	2	1
1024 x 768 / 1280x720 / 1280 x 960 / 1280x1024 / 1440x900 / 1600x900 / 1680x1050 / 1920x1056 / 1920x1080 / 2048x1536 / 2560x1600 / 2592x1936	2	2	2

2: Both System ID and Time are displayed.

1: When both System ID and Time are enabled, only System ID is displayed.

0: No items are displayed. Video area is too small to display OSD in large text.

Output Format

Output Format menu appears only when **Enable Preview** is turned on. Select the appropriate monitor output format based on the video output and monitor specification.

4. Remote Configuration

4.4 Audio Configuration

Setup Live View

System Video **Audio** Network Serial Event Preset Record User Camera

Audio Apply

Algorithm

Algorithm G.711 AAC

Bitrate 64kbps 128kbps

Mode

Mode

Input Gain

Input Gain

Algorithm

- **Algorithm**

Select the Audio Algorithm: **G.711** or **AAC**. G.711 and AAC is supported from client to camera direction. However, bi-directional audio communication is supported.

- **Bitrate**

Bitrate ranges from 64Kbps and 128kbps when AAC is selected. The sample rate is fixed to 8KHz and 32KHz for G.711 and AAC respectively. Note: when the camera is connected to a decoder, the decoder's audio algorithm should be set identically to transmit the audio properly.

- **Mode**

Select the Audio Operation Mode:

Mode	Action
Off	No Operation
Tx-Only	Transmit Only
Rx-Only	Receive Only
Tx & Rx	Transmit and Receive

- **Input Gain**

Audio Input Gain ranges from 0 to 31.

4. Remote Configuration

4.4 Network IP & Port Configuration

Setup Live View

System Video Audio Network Serial Event Preset Record User Camera

Network Apply

Local

IP Mode: Fixed IP

Local IP: 192.168.10.114

Local Gateway: 192.168.10.1

Local Subnet: 255.255.0.0

DNS

Obtain DNS server address automatically

Use the following DNS server addresses

Primary DNS Server: 168.126.63.1

Secondary DNS Server: 0.0.0.0

IPv6

IPv6 Address:

IPv6 Subnet Prefix Length: 0

IPv6 Default Gateway:

IPv6 LinkLocal: fe80::21c:63ff:fea7:10a/64

Port

Base Port: 2222 (1025~65535)

HTTP Port: 80 (80, 1025~65535)

HTTPS Port: 443 (443, 1025~65535)

RTSP Port: 554 (554, 1025~65535)

Discovery

UPNP: Off On

Zeroconf: Off On

WS Discovery: Off On

Authentication

RTSP Authentication: Off On

HTTPAPI Authentication: Off On

One-way Streaming

Mode: Off

SNMP

SNMP Listen port: 0 (0, 161, 1025~65535)

SNMP Trap Destination IP: 0.0.0.0

SNMP Trap Destination Port: 0 (0, 162, 1025~65535)

Multicast

Multicast IP: 224.10.0.2 (224.0.0.0 ~ 239.255.255.255)

DDNS

DDNS Server: None TrueDNS DynDNS Vdyn

Check IP Disable

Bitrate Control

Flow Control Mode: Suppression Mode

IP Filtering Setup

IP Filtering Setup: IP Filtering Setup

Address Information

Current IP: 192.168.10.114

Current Domain: Not RegisteredB

MAC Address: 00:1C:63:A7:01:0A

Connecting

4. Remote Configuration

Local

- **IP Mode**

Select the IP Mode: **Fixed IP** or **DHCP**

Depending on the selected mode, the following configuration applies:

IP Mode	Selection	Description
Fixed IP	Local IP	Fixed IP Address
	Local Gateway	Gateway IP Address
	Local Subnet	Subnet Mask
DHCP	N/A	

Contact your ISP provider or network manager for IP address information.

DNS

- **Obtain DNS Encoder Address automatically**

Find DNS Encoder Address automatically when IP Mode is set to DHCP.

- **Use the following DNS Encoder Address**

Enter the DNS Encoder IP Address: **Primary** or **Secondary DNS Encoder**

Domain Name System (DNS) is a database system that translates a computer's fully qualified domain name into an IP address. Networked computers use IP addresses to locate and connect to each other, but IP addresses can be difficult for people to remember. For example, on the web, it's much easier to remember the domain name `www.amazon.com` than it is to remember its corresponding IP address (`207.171.166.48`). Each organization that maintains a computer network will have at least one server handling DNS queries. That server, called a name server, will hold a list of all the IP addresses within its network, plus a cache of IP addresses for recently accessed computers outside the network.

IPv6

- **IPv6 Address:** Enter the designated Ipv6 address.
- **IPv6 Subnet Prefix Length:** Enter the bit number for the Ipv6 subnet.
- **IPv6 Default Gateway:** Enter the designated Ipv6 gateway.
- **IPv6 Link Local:** Display the Ipv6 link local.

Port

- **Base Port (1025 - 65535)**

Enter the Base Port Number: Network Base Port is used for communication with remote clients. In order for the IP Camera and remote systems to be connected, the port number must be identically configured for the IP Camera side and client side.

- **HTTP Port (80, 1025 - 65535)**

Enter HTTP port used for a web-based connection.

- **HTTPS Port (443, 1025 - 65535)**

Enter HTTPS port used for a secured HTTP connection.

- **RTSP Port (554, 1025 - 65535)**

Enter RTSP port used for RTSP-based connection. The default TRSP port is 554.

- **RTSP (Real Time Streaming Protocol)** is a standard for media streaming between encoder and client.

4. Remote Configuration

Discovery

- **UPNP**

When **UPNP** is ON, it allows the discovery of the client according to UPNP (Universal Plug and Play) Protocol.

- **Zeroconf**

When **Zeroconf** is ON, it allows the discovery of the client according to Zeroconf Protocol.

- **WS Discovery**

Discovery function based on web service is enabled. It allows the discovery by the client SW which is supporting Onvif.

Authentication

- **RTSP Authentication**

If RTSP Authentication is **ON**, the client side user will need to User ID and Password.

- **HTTP API Authentication**

When HTTP API Authentication is **ON**, HTTP Authentication is verified for all clients with HTTP API.

One-Way Streaming

- This IP Camera provides two kinds of one-way (unidirectional) streaming based on UTP to clients: **RTSP** and **MPEG-TS**. Both are types of broadcasting where traffic from clients to an encoder is not generated at all.

- **RTP (Real-Time Transport Protocol)** is an Internet Protocol used for transmitting single real-time multimedia data such as audio and video to a select group of connected clients. Normally RTSP uses RTP to format packets of multimedia content. The **RTP** menu is used when the RTP only is streaming without an RTSP connection. RTP stream will be transmitted to the destination set. The **SDP** (Session Description Protocol) file can be found in the encoder and a client can retrieve it using the http connection.

- **Destination IP:** Set the IP Address of the destination system receiving the RTP Stream. If the system is a decoder, RTSP authentication information can be found in the middle of the RTSP URL: rtsp://**admin:1234**@192.168.10.100:554/video1

- **Destination Port:** Set the port of the destination system receiving the TRP stream.

- **User Name:** Enter the user name that will be used as a session name in the SDP file.

- **File Name:** Enter the file name that will be used as the name of the SDP file. When this is entered, it can be accessed through

- <http://ServerAddress/filename>

4. Remote Configuration

Mode	RTP	
Destination IP	192.168.10.14	
Destination Port	1026	(0, 1026~65534, Even number only)
User Name	Office	
File Name	ch0.sdp	

• **MPEG-TS** is the standard format for the transmission and storage of audio, video, and data, and is used in broadcast systems such as DVB and ATSC. **Transport Stream** is specified in MPEG-2 Part 1 Systems (formally known as ISO/IEC standard 13818-1 or ITU-T Rec. H.222.0). Transport Stream specifies a container format encapsulating packetized elementary streams with error correction and stream synchronization features for maintaining transmission integrity when the signal is degraded. Although MPEG-TS supports AAC as the audio algorithm, only video is streamed when audio algorithm is set to G.711.

- **Destination IP:** Set the IP Address of the Destination System which will receive MPEG-TS stream.
- **Destination Port:** Set the Port of the Destination System which will receive MPEG-TS stream.

Mode	MPEG-TS	
Destination IP	192.168.10.14	
Destination Port	1026	(0, 1026~65534, Even number only)

SNMP

SNMP (Simple Network Management Protocol) is compatible with both **SNMPv1** and **SNMPvec**. Settings for using SNMP are as follows:

- **SNMP Listen Port (0, 161, 1025 - 65535)**

This port is for connecting an external device as an SNMP client. SNMP is not used when the value is 0.

- **SNMP Trap Destination IP**

Set the SNMP Trap Destination IP.

- **SNMP Trap Destination Port (0, 162, 1025 - 65535)**

Set the SNMP Trap Destination Port. SNMP is not used when the value is 0.

Simple Network Management Protocol (SNMP) is used by Network Management Systems to communicate with network elements. SNMP lets TCP/IP-Based Network Management clients use a TCP/IP-Based internetwork to exchange information about the configuration and status of nodes. SNMP can also generate trap messages used to report significant TCP/IP events asynchronously to interested clients. For Example: a router could send a message if one of its redundant power supplies fails or a printer could send an SNMP trap when it is out of paper.

M

4. Remote Configuration

Multicast

- **Multicast IP**

The Multicast menu is used for configuring the Multicast IP Address where the media stream is delivered when a Decoder, VMS or NVR software is connected in the Multicast Mode. The Multicast IP Address selection range is between 224.0.0.0 and 239.255.255.255. The selection can be used only when the media protocol is set to Multicast.

DDNS

Select DDNS (Dynamic DNS) Encoder to use. One of the two can be selected:

- **DynDNS**

DynDNS service is used in this mode. Refer to www.dyndns.org for details. ID, Password and Domain name are needed when DynDNS is set.

Dynamic DNS is a method, protocol, or network service that provides the capability for a networked device, such as a router or computer system using the Internet Protocol Suite, to notify a domain name server to change, in real time (ad-hoc) the active DNS configuration of its configured hostnames, addresses or other information stored in DNS.

- **Vdyn**

Vdyn is a DDNS service provided by Visionica (<http://visionica.com>). No further configuration is required for using this service. It internally uses the MAC address for the registration. When it succeeds, the domain name of the form **001C63A607EC.visionica.info** is displayed on Current Domain entry of the Network page. Email setting is not mandatory.

- **Check IP Disable**

If “Check IP Disable” is selected, it will skip to check it’s own IP. In **Fixed IP Mode**, the set IP will be registered on the DDNS Encoder. In **DHCP Mode**, a dynamically assigned IP will be registered on the DDNS Encoder. Normally Check IP Disable should be unchecked in order to obtain the public IP in the network.

Bitrate Control

When more than one device is connected to the camera, due to the bandwidth differences, some do not have enough bandwidth to receive the encoded stream completely. In this case, it is possible to select the video options:

- **Frame Drop Mode:** Encoding is performed strictly according to video settings. When a device is connected through a network with less bandwidth, some frames may be dropped.
- **Suppression Mode:** Encoding bitrate and frame rate are adjusted so frames are not dropped even when the network bandwidths are limited on some devices. In this case, all devices can be affected by the averaged bitrate and frame rate.

4. Remote Configuration

Address Information

Network information is displayed (read only):

- **IP Address:** Camera IP address is displayed. This information is useful when the camera's IP mode is set to DHCP.
- **Domain Name:** If the camera is registered to the DDNS server, the registered domain name is displayed.
- **MAC Address:** Displays the MAC address of the camera. If the camera is registered to the DDNS server, the MAC address is used for DDNS registration.
- **Connecting:** Device IP Addresses that are currently connected to system are displayed.

4. Remote Configuration

4.5 Serial Configuration

Setup Live View

SystemVideoAudioNetworkSerialEventPresetRecordUserCamera

Serial

Apply

COM2 (RS-485 Port)

Protocol RS-485

Bitrate 2400bps

Data Bit 8Bits

Parity None

Stop Bit 1Bits

PTZ

PTZ Type Pelco-D

PTZ ID 1

PTZ Port COM2

Sensor Type

Sensor 1 Off N/O N/C

Sensor Schedule

Select Sensor Off Sensor On

Sensor 1

	0	1	2	3	4	5	6	7	8	9	10	11	12	13	14	15	16	17	18	19	20	21	22	23
SUN																								
MON																								
TUE																								
WED																								
THU																								
FRI																								
SAT																								

Serial Port Configuration

Serial Port Information

This camera supports one RS-485 serial port. By default, Pelco-D protocol is used with 2400bps.

4. Remote Configuration

Sensor Type

There is one sensor input port on this IP camera. The sensor port can be configured as follows:

Function	Operation
OFF	Not used
NO (Normally Open)	The port is normally open and activated when closed.
NC (Normally Closed)	The port is normally closed and activated when opened.

The function of the sensor port is set based on type of the sensor connected.

Sensor Schedule

Choose **Sensor OFF** or **Sensor ON** and select cells to set Sensor Schedule for the day and hour.

- Click desired "Cell" to set schedule.

	0	1	2	3	4	5	6	7	8	9	10	11	12	13	14	15	16	17	18	19	20	21	22	23	
SUN																									
MON																									
TUE							■																		
WED																									
THU																									
FRI																									
SAT																									

- Click desired "Time Line or Date Line" to set schedule.

	0	1	2	3	4	5	6	7	8	9	10	11	12	13	14	15	16	17	18	19	20	21	22	23	
SUN															■										
MON																									
TUE							■																		
WED																									
THU	■	■	■	■	■	■	■	■	■	■	■	■	■	■	■	■	■	■	■	■	■	■	■	■	■
FRI																									
SAT															■										

- To set all cells in the schedule, click below "Empty Cell".

	0	1	2	3	4	5	6	7	8	9	10	11	12	13	14	15	16	17	18	19	20	21	22	23	
SUN	■	■	■	■	■	■	■	■	■	■	■	■	■	■	■	■	■	■	■	■	■	■	■	■	■
MON	■	■	■	■	■	■	■	■	■	■	■	■	■	■	■	■	■	■	■	■	■	■	■	■	■
TUE	■	■	■	■	■	■	■	■	■	■	■	■	■	■	■	■	■	■	■	■	■	■	■	■	■
WED	■	■	■	■	■	■	■	■	■	■	■	■	■	■	■	■	■	■	■	■	■	■	■	■	■
THU	■	■	■	■	■	■	■	■	■	■	■	■	■	■	■	■	■	■	■	■	■	■	■	■	■
FRI	■	■	■	■	■	■	■	■	■	■	■	■	■	■	■	■	■	■	■	■	■	■	■	■	■
SAT	■	■	■	■	■	■	■	■	■	■	■	■	■	■	■	■	■	■	■	■	■	■	■	■	■

4. Remote Configuration

4.6 Event Configuration

Setup Live View

System Video Audio Network Serial **Event** Preset Record User Camera

Event

Apply

Local

Sensor Alarm E-mail FTP No Preset v

On Video Loss Alarm E-mail FTP No Preset v

On Motion Alarm E-mail FTP No Preset v

Remote

Sensor1 Alarm E-mail FTP No Preset v

Sensor2 Alarm E-mail FTP No Preset v

Sensor3 Alarm E-mail FTP No Preset v

Sensor4 Alarm E-mail FTP No Preset v

On Disconnect

On Disconnect Alarm E-mail FTP No Preset v

Duration

Alarm 1sec v

E-mail Notification

Server Address

Port 25 (25, 465, 1025~65535)

Sender Address

Authentication on SMTP server Off On

ID

Password

SSL Disable Enable

Destination Address

Video Clip Attaching Off Primary Video Secondary Video JPEG Capture

Number of Frame 1 (1 ~ 10)

E-mail Test

FTP Upload

Server Address

Port 21 (21, 1025~65535)

ID

Password

FTP Filename

FTP Base Directory

Upload Video Primary Video Secondary Video JPEG Capture

Number of Frame 1 (1 ~ 10)

Continuous Upload Off On

Upload Duration 10 sec (Max 300)

Upload Interval 300 sec (Max 3600)

FTP Test

4. Remote Configuration

DISK

At least 1GB SD memory is recommended. Either EXT3 or FAT32 file system can be used. A disk with either EXT3 or FAT32 file system can be read in Linux PC. However, only FAT32 file system can be read in Windows PC.

Less than 4Mbps bitrate is recommended when you record and monitor video simultaneously since frame dropping may happen due to performance limitation.

Disk Information

Restart the system after connecting an SD card. During rebooting, the system reads & initializes the status of disk. Once the initialization is finished, the status is shown on the **Record** page of the web-based setup.



Refer to the chart below for Disk Status:

Disk Status	Description
Disk Error Detected	Error
No Disk	Disk is not connected to the system.
Searching Disk Information	Checking for disk status. Refresh the page and wait until status is changed.
Mounting and Recovering Disk	Performing recovery process when disk is damaged. This could take seconds to minutes to recover.
Disk Format Needed	Disk is attached but the file type is unknown or damaged.
Unknown Disk Type Detected	Disk is attached but the file type is unknown or damaged.
USB Disk Available	Available to be used for recording.
Disk removed or in abnormal state	Disk is detached during operation or damage is found on the file system. If detected while disk is connected, formatting the disk is recommended.

4. Remote Configuration

General

Use Record

- **Off**: Recording function is not used when **OFF** is selected.
- **Use Disk**: Recording is enabled and data will be written to a disk.
- **Use FTP**: Recording is enabled and data will be uploaded to an FTP server. In this mode, FTP upload by event is automatically disabled.

Select Video

- Select video stream to record.

Manual Record

- When **ON** is selected, recording is on regardless of schedule.

Overwrite

- When the disk becomes full, the oldest data is deleted automatically. This only applies when **Use Record** is set to **Use Disk**.

Max File Size/ Max File Length

- **Max File Size** option is for limiting the size of AVI file. If a small file size is set, small files will be generated but the number of files will be increased. **Max File Length** option is for limiting the time of the AVI file. If the size of a file reaches the **Max File Size** or the duration of the recording reaches the **Max File Length**, a new file is created.

Automatically Backup to FTP

- Recorded disk data can be uploaded to an FTP server automatically for backup. FTP server is configured on the Event page. This only applies when **Use Record** is set to **Use Disk**.

Erase After Backup

- Data is deleted in the disk automatically after being uploaded to the FTP server. This only applies when **Automatically Backup to FTP** is used.

Start Time of Backup Data

- Specify the time when Backup to FTP Disk should begin. This time can change based on the current schedule. This function only applies when **Automatically Backup to FTP** is selected.

FTP Base Directory

- Specify the name of the directory to be created in the FTP server. This only applies when **Use Record** is set to **Use FTP**.

4. Remote Configuration

Event Type

Three Recording Modes are supported: **Continuous**, **Event**, and **Disconnect**. Event Recording options allow event types to be selected for several events. Selected event type is used for configuring the schedule table. Up to 4 event types can be configured and each event type can be a combination of sensor, video loss and motion event.

Pre-Event Time

- Specify the recording duration before an event happens.

Post-Event Time

- Specify the duration after the event is cleared.

Schedule Table

- Actual recording mode is determined by the **Schedule Table** where recording mode is configured by the day and hour.

Recording Mode options:

- **Record Off**: No recording.
- **Continuous**: Records continuously.
- **Disconnect**: Recording is started when the system loses connection to the last device (Decoder, VMS/NVR, etc). When multiple devices are used and only one is disconnected, the others will continue to record.
- **Event Type**: Records when Event Type configuration is applied.

Checking Recording Status

Recording status can be checked on the main view page.



Search and Playback

Recorded video and audio data can be saved as an AVI file on the disk. In general, one AVI file is created per event recording. However, it is possible to merge a series of recorded data to a single AVI file depending on pre/post event time settings. The size of the file is limited to 10-200MB or 10 minutes.

4. Remote Configuration

- **Search**

An actual recording doesn't appear until the recording is completed. With Continuous Recording, a file will be shown after 10 minutes and a new file is generated every 10 minutes after that.

1. Press **Search Page** button on the **Record** setup page. The data will be displayed with recorded dates as shown below:



2. Chose the appropriate date and the list of AVI files will be shown.
3. The files are named as: "**Date Begin Time End Time.avi**".



4. Press **Root** to move back to the page with the date list.

- **Playback**

1. Selecting an AVI file will show a dialog for opening or saving the file.

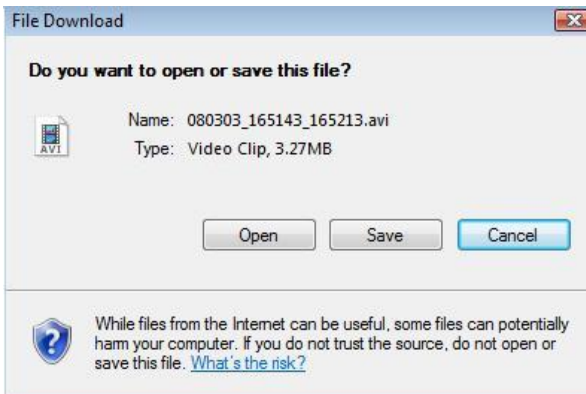

4. Remote Configuration

- The **Save** button will store the file. The AVI file can be played with Windows Media Player.

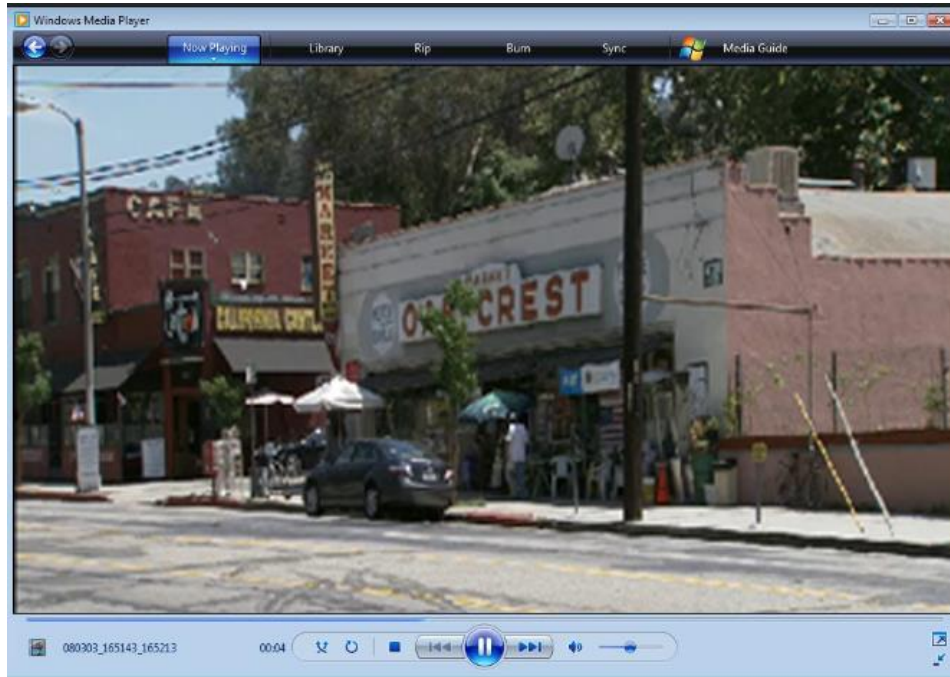

- The **Open** button will download and automatically play with the file with Windows Media Player.
- Another connection through web is disabled during downloading and it is also not allowed to download two AVI files at the same time.

- Deletion of Data**

- To delete recorded files, select appropriate files and press **Delete** button.

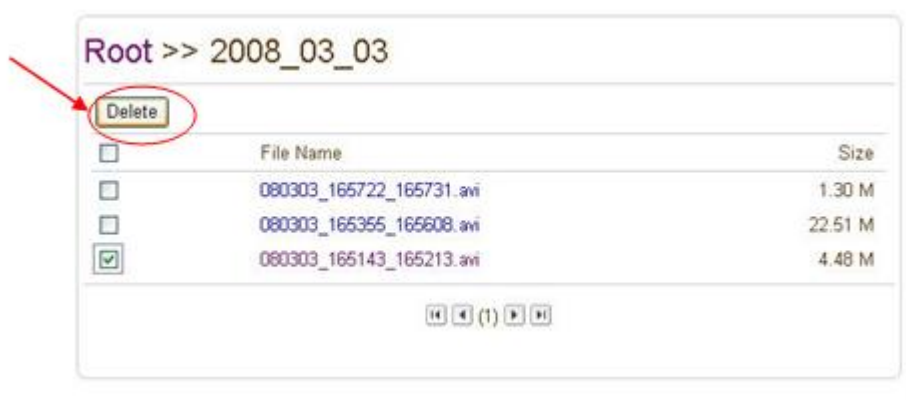

- It is possible to delete multiple files at once.

4. Remote Configuration

4.7 User Configuration

Setup Live View

System Video Audio Network Serial Event Preset Record **User** Camera

User

User List

ID	Privilege Level	
admin	Admin	<input checked="" type="radio"/>

Login Policy

Skip Login Disable Enable

Privilege Level After Login Skipped: Admin

User List

User can be registered and privilege level of a user can be specified. User configuration is allowed only to admin user. Max 16 users can be registered and each user can have one of four privileges.

Privilege	Allowed Operations	Remarks
Admin	All Operations	User ID = Admin
Manager	All Operations except for User Configuration	
User	Live Viewing and PTZ Control	
Guest	Live Viewing Only	

- **Add User**

Press **Add** button and this window will appear:

Setup Live View

System Video Audio Network Serial Event Preset Record **User** Camera

Add User

ID	Door
Password	••••
Privilege Level	Manager

Enter User ID and password (Up to 15 characters) and select **Privilege Level**.

4. Remote Configuration

- **Delete User**

Select the User to be deleted and press **Delete** button.

- **Change Password**

Press **Modify Password** button and this window will appear:

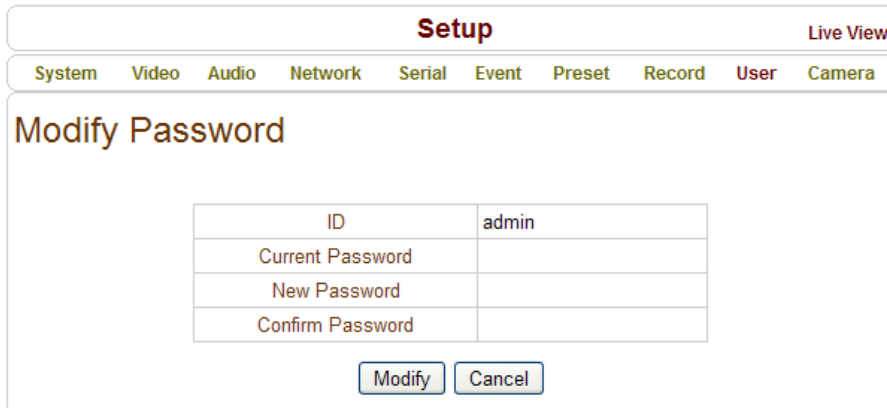

The screenshot shows a web interface titled "Setup" with a "Live View" link in the top right. A navigation bar contains tabs for System, Video, Audio, Network, Serial, Event, Preset, Record, User, and Camera. The "User" tab is selected. The main content area is titled "Modify Password" and contains a table with the following fields:

ID	admin
Current Password	
New Password	
Confirm Password	

Below the table are two buttons: "Modify" and "Cancel".

Enter the current password and then set a new password.

- **Modify Privilege Level**

Press **Modify Privilege** button to change User level. Privilege level can't be changed for Admin User.



The screenshot shows a web interface titled "Setup" with a "Live View" link in the top right. A navigation bar contains tabs for System, Video, Audio, Network, Serial, Event, Preset, Record, User, and Camera. The "User" tab is selected. The main content area is titled "Modify Privilege Level" and contains a table with the following fields:

ID	chris
Privilege Level	Manager

Below the table are two buttons: "Modify" and "Cancel".

Login Policy

- **Authentication**

HTTP authentication based on RFC 2617(HTTP Authentication: Basic and Digest Access Authentication) is supported.

- **Login Policy**

Skip Login provides for convenient access to the encoder when authentication is not required. When Skip Login is set to **Enable**, login step is skipped. The privilege level after login in this way is determined by the setting of **Privilege Level After Login Skipped**.

4. Remote Configuration

4.8 Camera Configuration

Setup Live View

SystemVideoAudioNetworkSerialEventPresetRecordUserCamera

Camera

Apply

Flip
Horizontal Flip Off On
Vertical Flip Off On

AEWB(Auto Exposure & Auto White Balance)
AEWB Mode AEWB
AE Mode Auto

True Day&Night and Filter
TDN Mode Threshold (Current Value 184)
Night-> Day Threshold (Def:40) 40

Day -> Night Threshold (Def:20) 20

Noise Filter Mode Interworking TDN
Grey Mode Interworking TDN
Shutter Speed Mode Interworking TDN
Shutter Speed Value 1/30 (sec)

IRIS
Mode Auto

Other Setting
Brightness(Def:127) 127

Contrast(Def:127) 127

Frequency Mode 60 Hz

4. Remote Configuration

Flip

- **Horizontal Flip**

The image will be flipped horizontally when Horizontal Flip is ON.

- **Vertical Flip**

The image will be flipped vertically when Vertical Flip is ON.

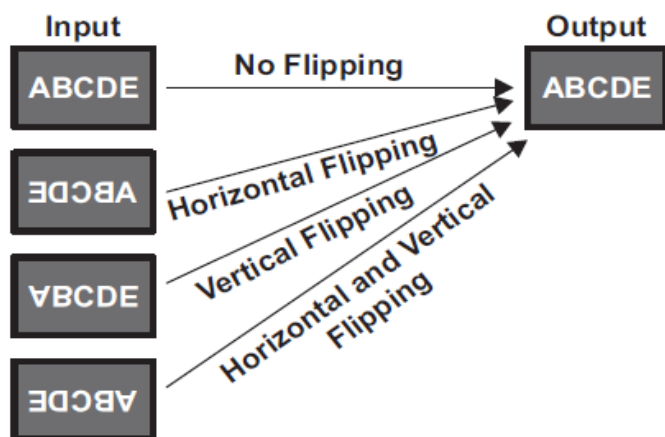

Auto Exposure & Auto White Balance (AE & AWB)

AE: Control gain, iris, and exposure is automatically adjusted.

AWB: Control RGB gain for color balance is automatically adjusted.

- **AEWB Mode**

AEWB: AE & AWB function is enabled.

AE: Only AE function is enabled.

AWB: Only AWB function is enabled.

None: AE & AWB function is disabled.

- **AWB Index**

Indoor: Select this option when camera is installed indoors.

Outdoor: Select this option when camera is installed at outdoors.

- **AE Index**

Day: Select this option for a better quality image.

Night: Select this option for a brighter image.

- **AE Mode**

Auto: AE will adjust brightness values automatically.

Manual: AE adjusts brightness values individually - AE Target, AE MAX and AE MIN.

4. Remote Configuration

- **AE Target**

AE Target can be adjusted from 0-40 on AE Mode. Lower value equals darker image.

- **AE MAX**

AE MAX can be adjusted from 0-45.

- **AE MIN**

AE MIN can be adjusted from 0-35.

The image becomes insensitive if the value is lower and sensitive if the value is larger with both AE MAX and AE MIN.

True Day & Night (TDN)

IP Camera will use the IR filter for image quality. IR filter is on during the day and off during night.

- **TDN Mode**

Threshold: TDN is controlled by day & night threshold value.

Auto: TDN is controlled by internal value.

Day: TDN is forced to day mode.

Night: TDN is forced to night mode.

- **Day Threshold**

The Day Threshold can be adjusted from 0-40. TDN is automatically set to Day but the IR Filter is turned on when the brightness is higher than the value.

- **Night Threshold**

The Night Threshold can be adjusted from 0-20. TDN is automatically set to Night but the IR Filter is turned on when the brightness is lower than the value.

- **Noise Filter Mode**

The Noise Filter Mode works in conjunction with TDN. The noise filter mode is on during the night and off during day.

On: Noise filter is always ON.

Off: Noise filter is always OFF.

- **Grey Mode**

The Grey Mode works in conjunction with TDN. The grey filter will remove color based on TDN at night and add color based on TDN during the day.

On: Color is always removed (gray image).

Off: Color is always added (color image).

4. Remote Configuration

- **Shutter Speed Mode**

Shutter Speed Mode is configured based on Shutter Speed Value. Enabling Shutter Speed Mode will produce a brighter video in a low illumination environment by sacrificing the framerate.

On: Shutter Speed setting is applied.

Off: Shutter Speed setting is not applied.

- **Shutter Speed Value**

Shutter Speed is selected from 1/30 sec to 1 sec. For Example: When 1/6 sec is selected, the image sensor is exposed for 1/6 sec and a max of 6 frames can be obtained for one second.

IRIS

IP Camera will support Auto IRIS Lens.

- **Mode**

Auto: IRIS is controlled by AE.

Open: IRIS forces max opening.

Close: IRIS forces closing.

Back Light Compensation (BLC)

If the background is bright, the subject will become dark on the monitor. This function allows the subject to still be identifiable.

- **Mode**

Off: BLC is disabled.

On: BLC is enabled.

- **Value**

Select the Value from 1-6.

Other Settings

- **Brightness**

The image brightness can be adjusted from 0-255; a higher value produces a brighter image. (127: default, 0: the darkest, 255: the brightest)

- **Contrast**

Adjust the image contrast by raising or lowering the value.
(127: default, 0: the weakest, 255: the strongest)

- **Frequency Mode**

Operation frequency can be selected to avoid a flickering under fluorescent light. The value can be either 50Hz or 60Hz. (127: default, 0: the weakest, 255: the strongest).

5. VS Manager

VS Manager is a program used for basic configuration, diagnostics and firmware upgrade of video encoders or IP encoders. **VS Manager** provides the following features:

- Finding Encoders on the LAN and assigning IP Addresses.
- Monitoring Server Status: Encoding/Decoding, Serial, Sensor, etc.
- Diagnostic Function: PING, Network Bandwidth Measurement, Video/Audio Output, Port Check, Serial Port Check.
- Firmware Upgrade.

VS Manager Software Download:

<http://www.lcdracks.com/servers-cameras/software/software.php>

1. Create a folder on your 'C' drive and download the file into that folder using the link above.
2. Copy and paste the link above into an Internet Explorer address window.
3. Right mouse click on the file and make a shortcut on your desktop (using "send to command")
4. Launch the application by double clicking on the desktop icon.
5. Login = admin, Password = 1234.

For Windows 7, 64 bit ONLY:

Once VS Manager installed, select IP Discovery, create servers.

On main page go to Tools, Options and change to this path below.

In the address window, after the word "Files" type a space then (x86).



6. Data Sheet

VS-7300 5 MP IP Box Camera



- 5 MP 1/2.5" 2592 x 1944 CMOS Image Sensor
- High Resolution Video streaming 2592 x 1944 @ 15fps
- H.264 & H.264 MJPEG Dual Streaming
- C/CS Lens Mount*
- True Day & Night (Motorized IR Cut Filter)
- Auto Iris (DC) lens control
- Integrated Video Motion Detection
- Built-in PoE (Power Over Ethernet: 802af)
- SD™ card recording
- Two-way Audio Communication (G.711/AAC)
- Motion Sensor Input & Alarm Output



INCLUDES POWER SUPPLY*

**required for applications not utilizing PoE*

6. Data Sheet

Specification Sheet

VS-7300 Specifications		
	Section	Specifications
Network	Network Interface	Ethernet 10/100Base-T (RJ-45)
	Network Protocol	TCP/IP, UDP, Multicast, DHCP, SMTP, HTTP, SNMP, RTP, RTSP
Camera	Image Sensor	1/2.5" CMOS Image sensor
	Lens	C/CS Mount selectable (Lens is not included)
	Max. Aperture Ratio	1:1.8
	Motion Image Stabilizer	On/Off
	Back Light compensation	On/Off
	Flip	Vertical Flip, Horizontal Flip
	Exposure	Flickerless, Metering, Mode, Aperture, Shutter Speed, Brightness
	Focus	Focus Range, Zoom Tracking
	White Balance Index	Auto, Indoor, Outdoor
	Image Quality	Sharpness, DNR, Chroma CR, Chroma CB, Hue CR, Hue CB
	Motion Detection	On/Off
Video	Standards	Main Stream: H.264 Secondary Stream: H.264/MJPEG
	Resolution	2592x1944, 2560x1600, 2048x1536, 2048x1080 ~ 176x120
	Max Frame Rate	MJPEG: 15fps @ 2592x1944, 18fps @ 2560x1600, 25fps @ 2048x1536, 30fps @ 2048x1080 ~ 176x120 H.264: 8fps @ 2592x1944, 10fps @ 2560x1600, 15fps @ 2048x1536, 30fps @ 2048x1080 ~ 176x120
	Bitrate	32 ~ 10,240 Kbps
	Algorithm	G.711, AAC
Audio	Input	1 x Line-In (Mini-Stereo)
	Output	1 x Line-Out (Mini-stereo)
	Sample Rate	G.711: 8kHz / AAC: 32kHz
	Bitrate	G.711: 64Kbps / AAC: 64Kbps, 128Kbps
	Port	1 x RS-485
Serial	Data Rate	2,400bps ~ 115,200bps
	Sensor Input	1 x NO Contact
Sensor/Alarm/etc.	Alarm Output	1 x NO Contact
	Reset Button	1 x Factory Reset Button
	System Status	LED
User Interface	System Status	LED
Software	True NVR/CMS	Live Monitoring, Recording, Search & Playback, Backup
Physical	Dimensions	103.5(W)mm x 70.3(L)mm x 70.6(H)mm
	Weight	437.0g (without Lens)
	Power Source	DC 12V/0.5A PoE: 802.3af
	Power Consumption	Max 6W

7. Appendix

Appendix A: Sensor and Alarm Port

Sensor Port

- **Terminal Type**
 - Voltage Rating: 150VAC
 - Current Rating : 2A
 - Color : Red
- **Sensor Signal Input Type**
 - NO Contact Signals
- **Connection to External Device**

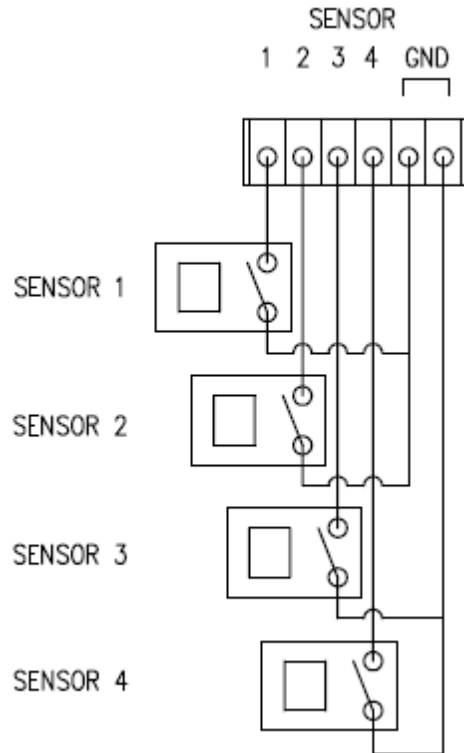

Alarm Port

- **Terminal Type**
 - Voltage Rating: 150VAC
 - Current Rating : 2A
- **Relay Type**
 - Contact Rating : 1A 30VDC
 - Switching Power : Max 30W 62.5VA
 - Switching Voltage : Max 60VDC
- **Alarm Signal Output Type**
 - NO/NC Contact Signals
- **Connection to External Device**

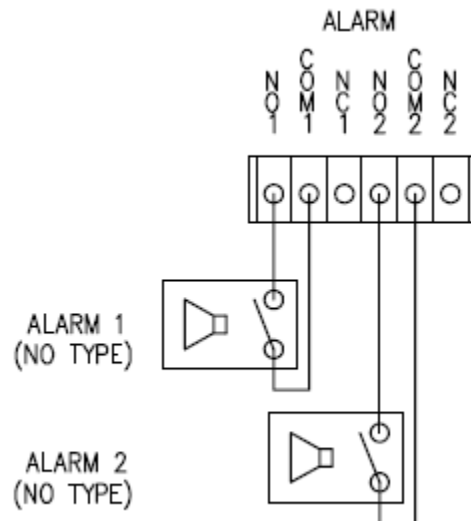

7. Appendix

Appendix B: Serial Port

RS-232 Port

- Terminal Type
- 3 PIN
- Pin Arrangement

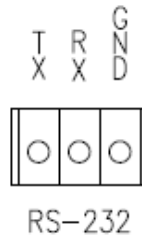

Pin Description:

Pin NO	Pin Name	Description
1	TX	RS232 TX(Transmit)
2	RX	RS232 RX(Receive)
3	GND	Ground

RS-422/485 Port

- Port Type
- 4 PIN
- Pin Diagram

RS-422/485 TERMINALS

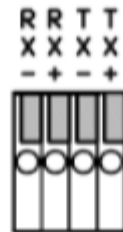

Pin Description:

Pin No.	Pin Name	Description
1	RX-	RS422 RX-
2	RX+	RS422 RX+
3	TX-	RS422 TX- or RS485 TRX- It is selectable by S/W Setup
4	TX+	RS422 TX+ or RS485 TRX+ It is selectable by S/W Setup

Marshall Electronics, Inc.

1910 East Maple Ave. El Segundo, CA 90245
Tel: (800) 800-6608 / (310) 333-0606 • Fax (310) 333-0688
www.LCDRacks.com • sales@lcdracks.com